

- 1) G.I. STEEL LID
- 2) 1"THK. RIGID INSULATION
- 3) EXTERIOR MANUAL RELEASE SHOWN
- 4) G.I. STEEL SMOKE VENT BASE
- 5) EYEBOLT & PULLEY ASSEMBLY
- 6) LIFTING SHOCK
- 7) LATCH ASSEMBLY
- 8) OPEN EYE TURNBUCKLE
- 9) G.I. STEEL GUTTER
- 10) STRIKER ASSEMBLY
- 11) 2X WIDE (1 1/2") CURB BY OTHERS
- 12) G.I. STEEL HINGE ASSEMBLY
- 13) LOWER SHOCK BRACKET
- 14) 0.080" TENSION SPRING
- 15) FUSIBLE LINK - SPECIFY TEMP
- 16) 0.060" 7 STRAND STEEL CABLE
- 17) G.I. STEEL SHOCK LOCK CHANNEL
- 18) G.I. STEEL DOME FRAME
- 19) EPDM BULB GASKET
- 20) VORTEX G.I. STL. CURB MOUNT BASE
- 21) INCLUDES RAIN BAFFLE & BIRD SCREEN STD.

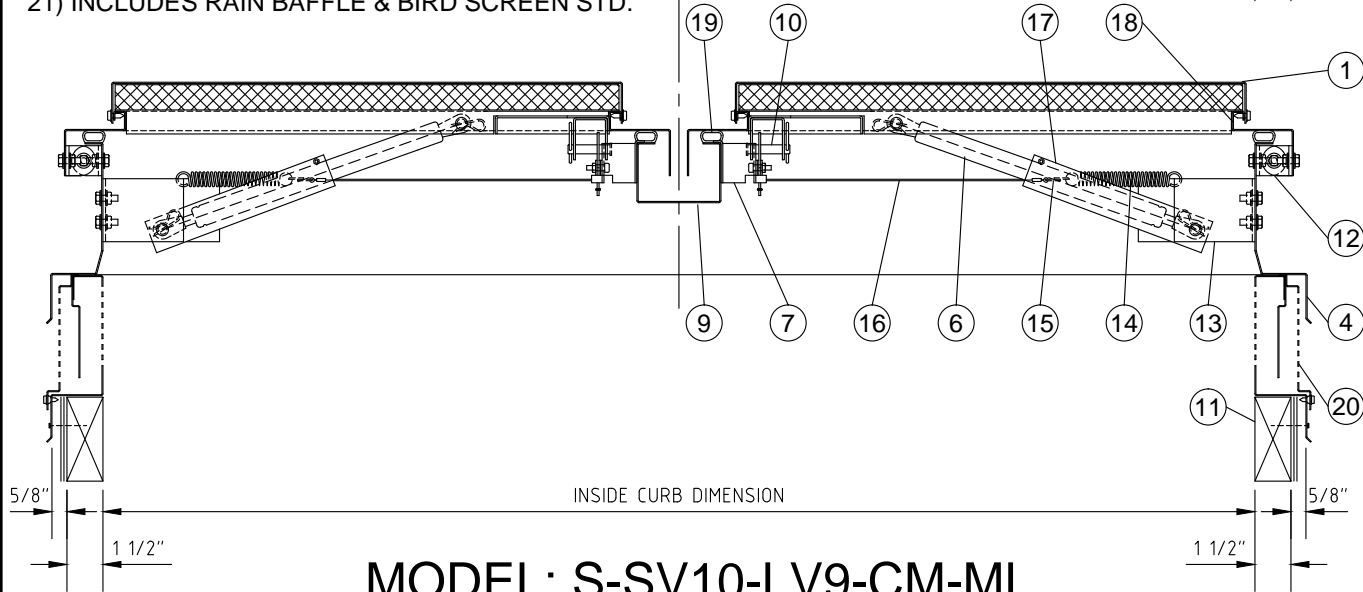
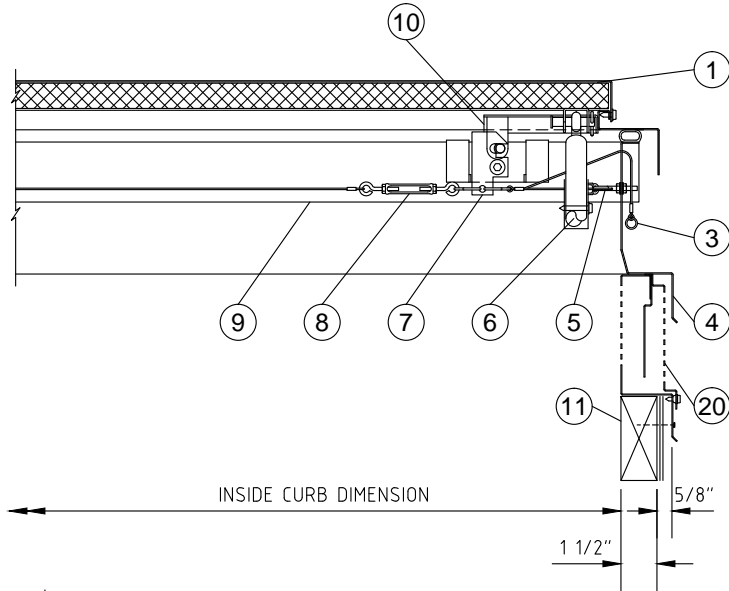

MODEL: S-SV10-LV9-CM-ML

SCALE : 1 1/2" = 1'-0"

SKYCO

SKYLIGHTS

949-629-4090

FRAME FINISH

G90 GALVANIZED

FUSIBLE LINK TEMP. OPTIONS

165° UL/FM 286° UL/FM OTHER

212° UL/FM 370° UL/FM

MANUAL RELEASE OPTIONS

INSIDE RELEASE

OUTSIDE RELEASE

BOTH

UNIT INCLUDES

RAIN BAFFLE

BIRD SCREEN

OPTIONS FOR:

INSECT SCREEN

DUST FILTER

MODEL	INSIDE CURB DIM.	QTY.
	SQUARE	
4848	48" x 48"	
	RECTANGULAR	
4896	48" x 96"	

10 PSF

CURB MOUNT STEEL FRAME VORTEX LOUVERED DUAL LID SMOKE VENT

PROJECT:	PROJECT ADDRESS:	APPROVED BY:	DATE:
CUSTOMER:	CUSTOMER PHONE:	REV. #	JOB #:
		DATE:	DRAWING #:
			SKSV-014